

616/626/636/646 LED KEYPAD CONNECTIONS

Panel/Keypad Connection

The “red”, “black”, “green” and “yellow” wires/connections should be connected to the corresponding colour labeled terminals on the control panel PC board. The blue wire is connected to the keypad zone and the orange wires are connected to the tamper switch.

Keypad Zone Connection

There are two possible keypad zone connections depending on whether an onboard or external 1K Ω EOL resistor is used (Jumper 2 [J2]):

1) Connection with an “external” 1K Ω EOL resistor Jumper 2 [J2] = IN (See Figure 1 and 3)
A 1K Ω EOL resistor must be connected in series with the signaling device with or without a tamper (in the example shown, a door contact) for the zone to be recognized.

2) Connection with an “onboard” 1K Ω EOL resistor Jumper 2 [J2] = OUT (See Figure 2 and 4)
No other EOL resistor is required in series with the signaling device (in this example, a door contact) for the zone to be recognized.

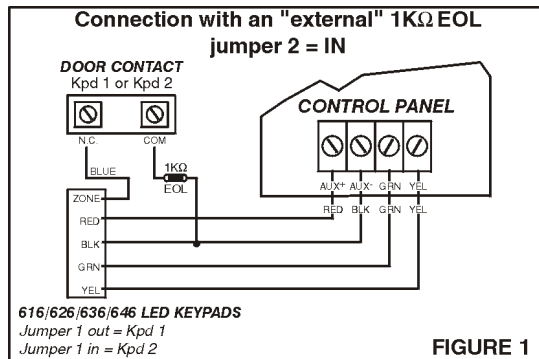

FIGURE 1

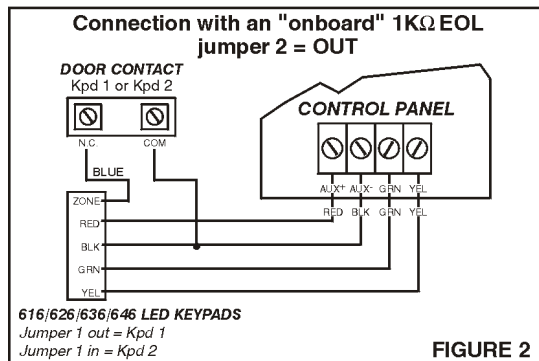

FIGURE 2

WARNING! Keypad zones should not be programmed as 24hr. zones

If you do not wish to use the keypad zone, connect the "blue" (zone terminal) wire to the "black" (com terminal) connector and remove the Jumper 2 (J2) = OUT).

Keypad zone selection:

Keypad zone can be set on keypad zone 1 or keypad zone 2.

To set the keypad zone on zone 1, J1 = OFF

To set the keypad zone on zone 2, J1 - ON

Panel setting:

Keypad zone supervision must be programmed on the control panel.

Software versions 2.00 to 2.20

Address **210**, key **[11]** for keypad 1

Address **210**, key **[12]** for keypad 2

Software versions 3.00 to 3.10

Address **090**, key **[11]** for keypad 1

Address **090**, key **[12]** for keypad 2

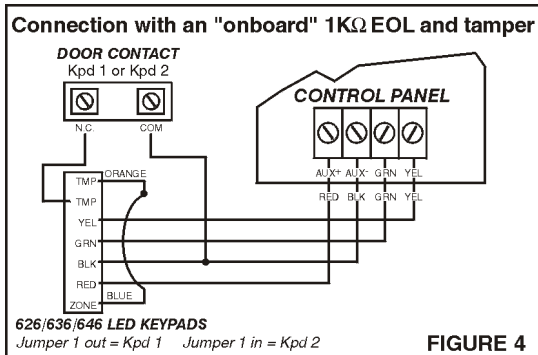
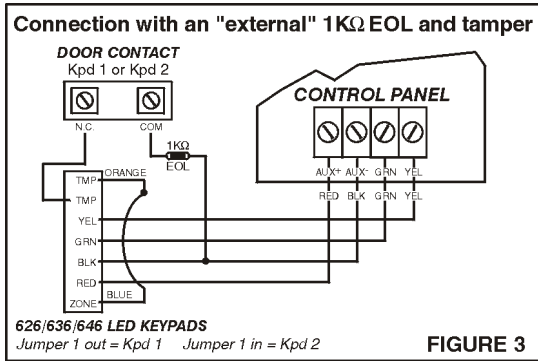

P A R A D O X
SECURITY SYSTEMS

780 Boul. Industriel, St-Eustache, Montréal,
Québec, Canada J7R 5V3
Fax: (450) 491-2313
<http://www.paradox.ca>

K6X6EA-02
Paradox Security Systems
Graphic Dept
PRINTED IN CANADA - 04/01