

BT-E4 connection diagram

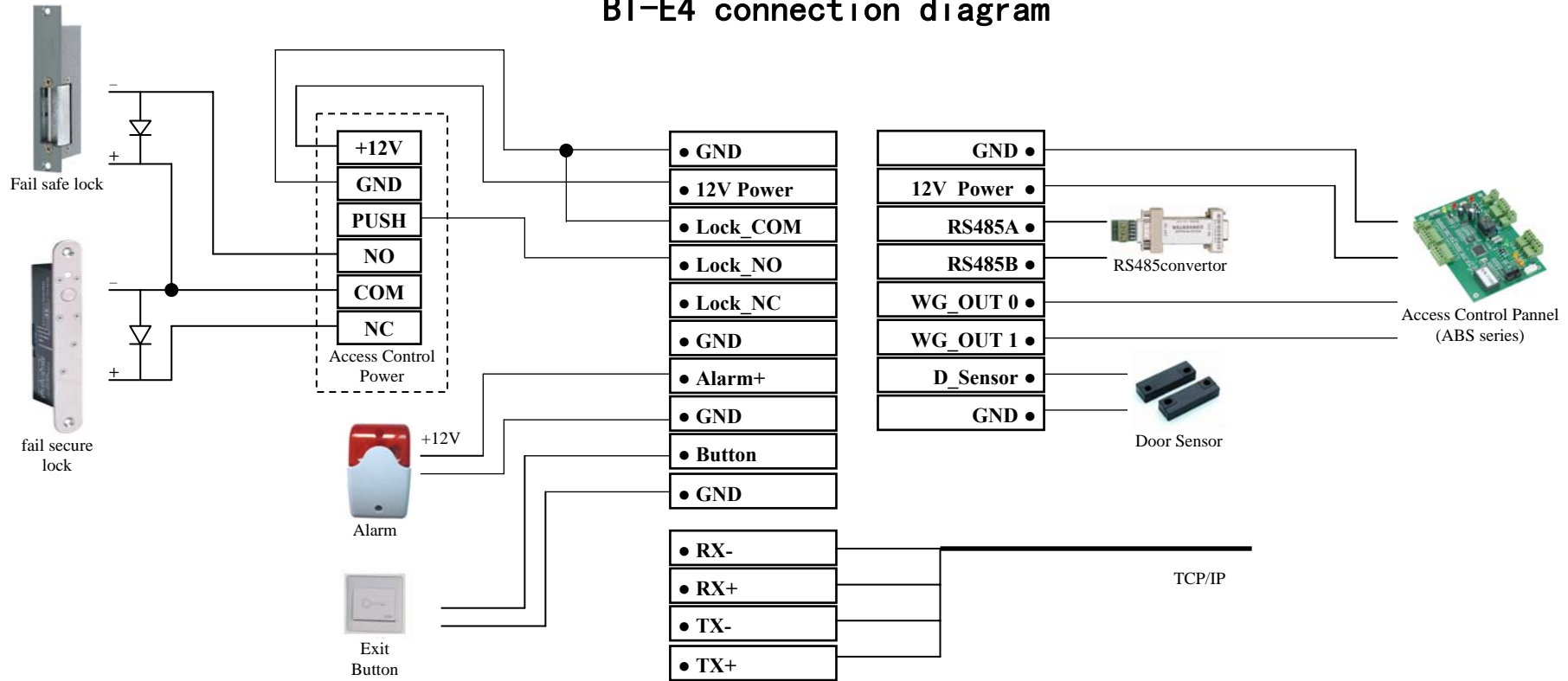

please open the steel cover, find the label sticker on the back of device, it tell the position of pins

the device support communication of Rs485,TCPIP, USB,and USB flash memory

it can work as an access controller, also it can work as a fingerprint reader for Access control Panel(which support WG26/34

if there is updating , it will make the pins different from the label sticker on the back of device, please refer the latest connection diagram

The Device Lock control relay standard is DC24V3A, if connecting the lock directly to the device without access control power, please don't exceed the standard

GND	Ground	GND	Ground
12V Power	Power input	12V Power	Power input
Lock_COM	Lock Ground Port	RS485A	RS48+
Lock_NO	Lock always-On Port	RS485B	RS485-
Lock_NC	Lock always-Off Port	WG_Out 0	Wiegand -
GND	Ground	WG_Out 1	Wiegand +
Alarm+	Alarm 12 V output	D_Sensor	Door sensor
GND	Ground	GND	Ground
Button	Exit button		
GND	Ground		